

GUIDE TO COMPATIBILITY & PROPER USAGE

COMPATIBILITY

The EdgeMate Pool Chair fits most in-ground pools, but, due to the diverse nature of pool design, not all of them.

And while no qualifying test is perfect, if you are able to answer yes to the following two questions, EdgeMate is likely to be compatible with your pool:

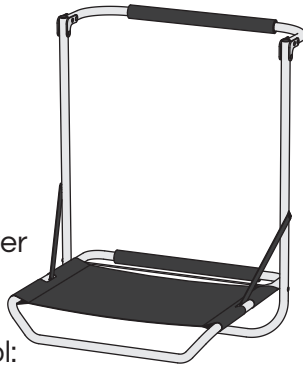

Question #1

Do you have a flat/level pool surface (coping)?

Question #2

Do you have a flat (vertical) pool wall?

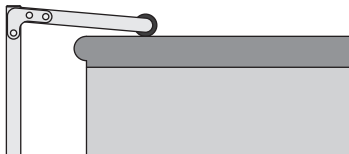
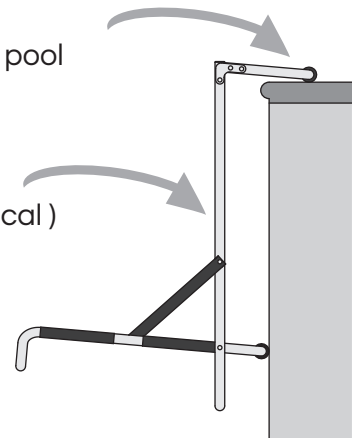

Here is a profile view of a compatible pool. Notice how the pad on the support bar has complete contact with the level pool surface (coping) and the uprights on the main frame (shown above) run parallel (alongside) to the pool wall. These create two stable touch points, one on the deck and one on the wall.

This is an example of a pool incompatible with EdgeMate.

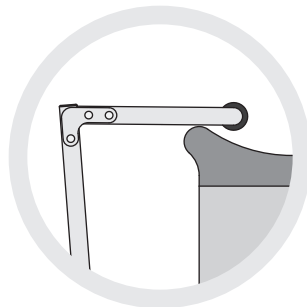
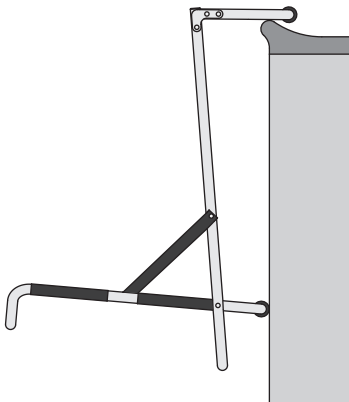

Due to the pool's sloped edge (coping), the pad on the support bar does not have contact with the surface. Therefore, the EdgeMate Pool Chair will NOT hold a stationary position.

EdgeMate is also not compatible with above ground pools, infinity-edge pools, or pools with a gutter.

PROPER USAGE

Sitting in EdgeMate is no different than sitting in a conventional chair. While a swimmer's height and water depth will often vary, one should always make a point of sitting down into EdgeMate.

If a swimmer has to step up on one foot (like they would a bar stool), they should position EdgeMate in more shallow water.

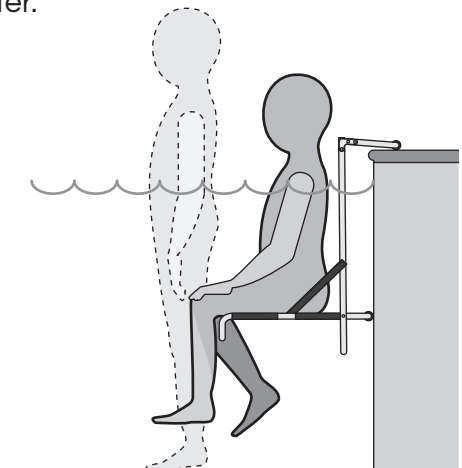

If you're still unsure if your pool is compatible, please contact us at info@edgematepoolchair.com. We're here to help!